

Modification of Lucent-RFTG REF1, pc-board Z3811-60001, Rev K980710, adding of a 10MHz-sinusoutput

Circuit description

The mentioned pc board contains a 5MHz-OCXO. The frequency of the OCXO is multiplied and filtered to 10 and 15MHz on the board. The 15MHz signal is connected to J4 in unit REF0 and REF1 likewise. This was the reference signal in the original application. In most cases however a frequency of 10MHz is preferred. Thus a very simple modification will be described here and after being executed a 10MHz sinus signal with a level of +5dBm @ 50Ω will be available at J4. No additional multipliers or mixers are needed.

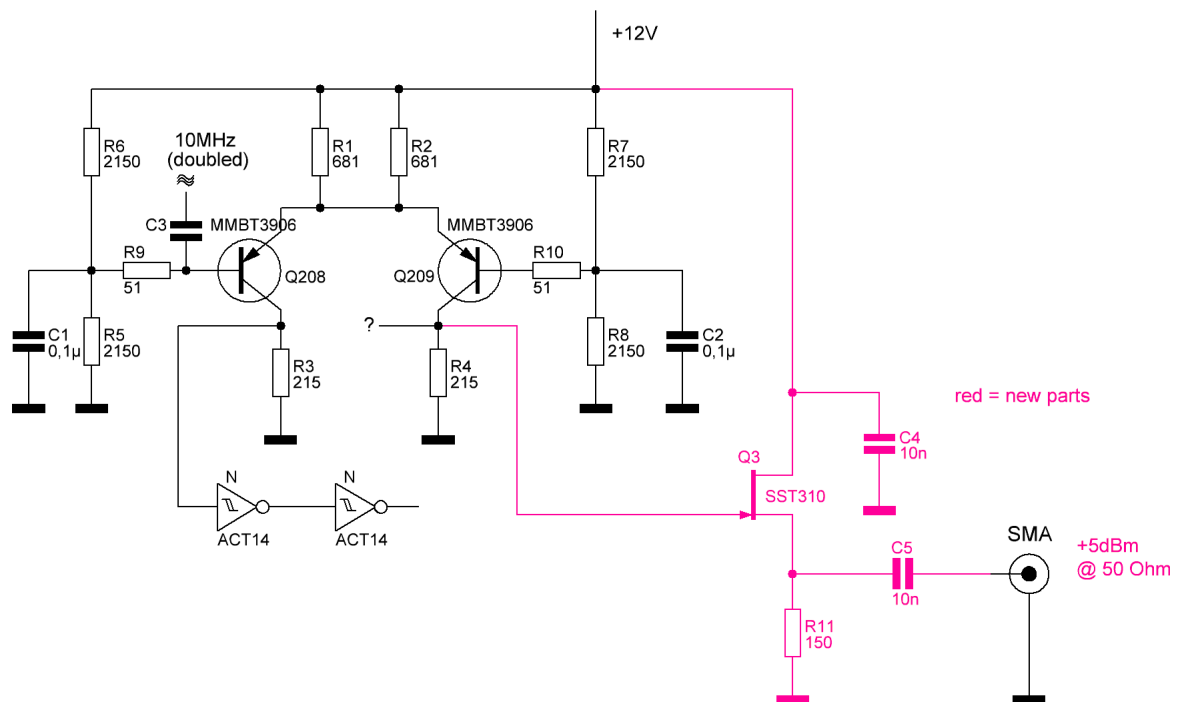

The available doubled 5MHz signal is already cleaned by a low pass filter and can be accessed at the differential amplifier formed by Q208 and Q209. All these components are very close to J4 furthermore. One output of the differential amplifier is connected to some Schmitt triggers of the ACT14, U206. The other output of the differential amplifier “disappears” in a buried via and without a circuit diagram it is nearly impossible (time-consuming at least) to track the signal. Both outputs deliver approximately 3V_{ss}, the dc-bias is 1.5V, just good for the Schmitt triggers. The output with the “unknown connection” is used and for “safety reasons” a source follower is used to buffer the signal and to avoid unwanted influence to other parts of the unit. The gate of the SST310 is directly connected to the collector of Q209. This way the bias of the FET is provided. Further components are only a source resistor (150Ω) and a dc block capacitor and decoupling capacitor for the drain dc supply, 10nF each. The amplitude of the output signal is +5...+6dBm @ 50Ω, harmonics are suppressed to less than -18dBc. A 5MHz signal appears at -80dBc. These data were measured only on 2 modified units and thus can differ a bit.

The modification

The practical modification has to be done as follows: remove the 2 covers of the unit REF1, remove all torx screws fixing the pc board. Attention: the GPS-receiver has to be removed too, as another torx screw is hidden underneath it. Now remove all screws and nuts and bolts which are fixing the D-SUB connectors, the SMA- and the TNC-connector on the front panel. The front panel itself remains fixed to the case. Now remove the pc board carefully by “tender” movements, sometimes it clamps a bit... The reassembly is done in reverse order.

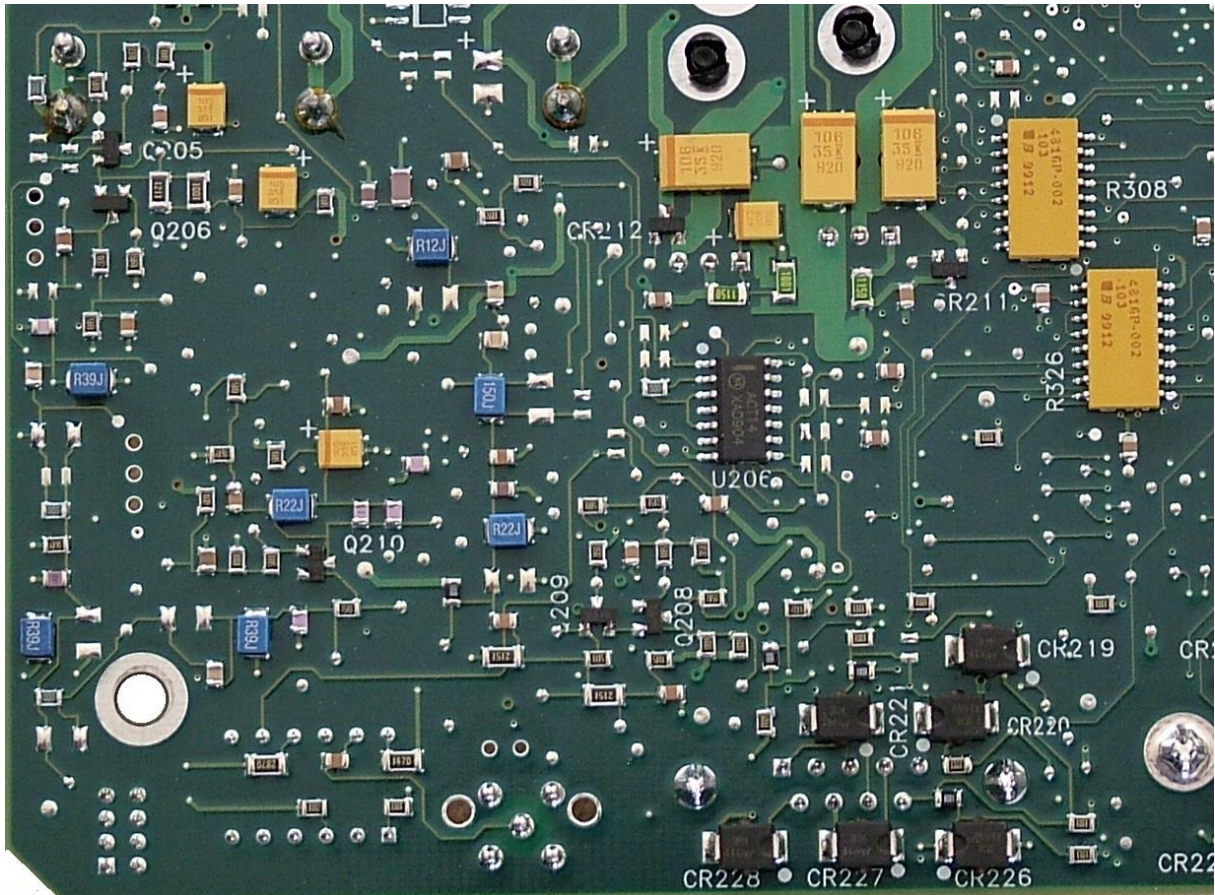

This picture shows the area of the bottom side of the dismantled pc board where the modifications have to be done. As the soldering of 0805 and SOT23 SMD components has to be done a suitable fine soldering iron and a tweezers will be necessary. The next photo shows the pc board and the position of the referred components.

