

# ENVELOPE / ASSEMBLY DRAWING

000000

## SPECIFICATION CONTROL DRAWING

THIS DRAWING CONTAINS INFORMATION PROPRIETARY TO RF INDUSTRIES, LTD. ANY UNAUTHORIZED USE OF THIS DRAWING IS EXPRESSLY PROHIBITED. ANY VIOLATION IS PUNISHABLE UNDER U.S. COPYRIGHT LAWS.

ALL DIMENSIONS ARE REFERENCE ONLY

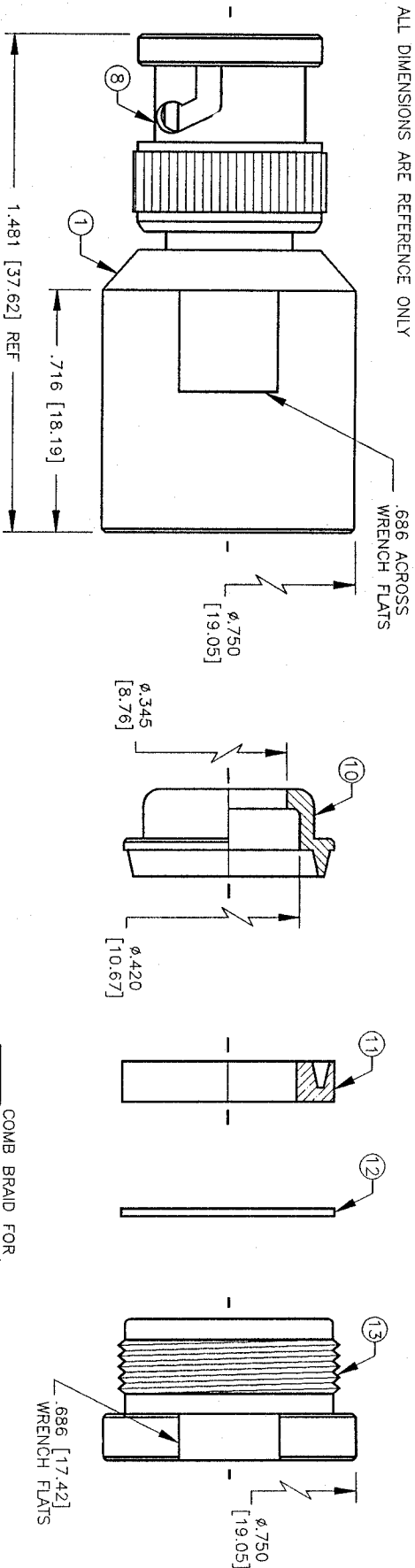

### SPECIFICATIONS:

IMPEDANCE: 50 OHMS  
 WORKING VOLTAGE: 500 VRMS @ SEA LEVEL  
 FREQUENCY RANGE: 0-4 GHZ  
 INSERTION LOSS: ≤ -.2 DB @ 3 GHZ  
 VSWR MAX: 1.4:1 @ 3 GHZ  
 FOR BELDEN 8214, 9913, 9913F, 9914, RG-8/U TYPE, RG-393/U,  
 CAROL C1180, TIMES AA-5886 & LMR-400 CABLE  
 INTERFACE PER MIL-STD-348A, SECTION 301.1

ITEM	DESCRIPTION	QTY	MATERIAL	FINISH
13	BACK NUT	1	BRASS	SILVER
12	WASHER	1	BRASS	SILVER
11	GASKET	1	S.I. RUBBER	RED
10	CLAMP	1	BRASS	SILVER
9	PRESS FIT WASHER	1	BRASS	SILVER
8	SHELL	1	BRASS	SILVER
7	WASHER	1	BRASS	SILVER
6	SPRING	1	SK-5	SILVER
5	SPLIT LOCK WASHER	1	BRASS	SILVER
4	GASKET	1	S.I. RUBBER	RED
3	DIELECTRIC	1	TEFLON	NONE
2	PIN	1	BRASS	GOLD
1	BODY	1	BRASS	SILVER

REV	DESCRIPTION	DATE	APPROVALS
B	STANDARDIZE		
C	CHANGE BODY DIMENSIONS THROUGHOUT		
D	CHANGE SHELL, BODY, PIN & DIE DIMENSIONS		
E	LENGTHEN DIE, PIN & BODY / ADD DIM TO CLAMP		

DIMENSIONS ARE IN INCHES AND [MILLIMETERS]

UNLESS OTHERWISE NOTED TOLERANCES ARE: DECIMALS DIAMETER

DRAWN: C. ZUNIGA  
 CHECKED: [Signature]  
 APP'D: [Signature]  
 P. BREAUX

6/23/99  
 9/11/92

**RF connectors**  
 DIVISION OF RF INDUSTRIES, LTD.

**RFB-1101-1S1**

BNC MALE CLAMP

7610 MIRAMAR RD  
 SAN DIEGO, CA 92126  
 (858)549-6340  
 (858)549-6345 FAX

SIZE: A  
 CABLE GROUP: 1  
 DWG NO.: 7799

SCALE: 2:1  
 CAD FILE: 13ARC B  
 SHEET: 1 OF 1